

# OPIRA-DAW-1100 ANIMAL CAGE CHANGING STATION

opira.com.au



Accredited for compliance with ISO/IEC 17025-testing

Protect operators from allergens and special odours during experiments.



### DAW-110 features:

- Two-way safety protection: with excellent ventilation system and negative pressure airflow, it can provide two-way safety protection for people, animals, environment, and objects during the process of animal cage change.
- Use high-quality materials: the work surface is made of 304 stainless steel, which can be quickly disassembled and cleaned up waste.
- Double-layer filtration system: primary and high-efficiency double-layer filtration system.
- Control system: LCD touch screen design, real-time dynamic display of the airflow speed of the workstation.
- Audio and visual alarm: Abnormal air flow velocity and Filter replacement .Transparent side glass windows maximise light and visibility inside the cabinet

The animal cage changing station is suitable for the replacement of animal cages in SPF animal rooms, the anatomy of experimental animals and the separation of tissues, etc. It adopts positive vertical flow, double primary effect and double high efficiency filtration design, which can prevent animals in the work area from being polluted by outside air. The double-sided open design facilitates simultaneous operation by multiple person. It is a safety protection device specially designed for animal research laboratories.

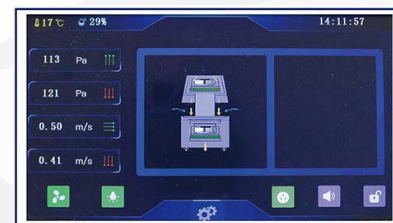

### Highlight LCD touch screen design:

Real-time dynamic display of the downflow velocity and inflow velocity, the overall operating time, the temperature and humidity, and the resistance of the air supply and exhaust filters.

CONTACT OPIRA NOW  
**1300 157 969**  
SOLUTIONS@OPIRA.COM.AU

**OPIRA BRISBANE**  
32 DIVIDEND ST  
MANSFIELD, QLD 4122

**OPIRA MELBOURNE**  
25 GRAHAM RD  
CLAYTON SOUTH, VIC 3169

**OPIRA PERTH**  
9 EARLSTON PLACE  
BOORAGOON, WA 6154

**OPIRA SYDNEY**  
20 DUKE ST  
FORESTVILLE, NSW 2087



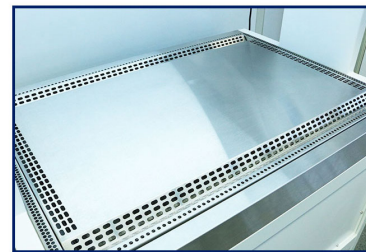
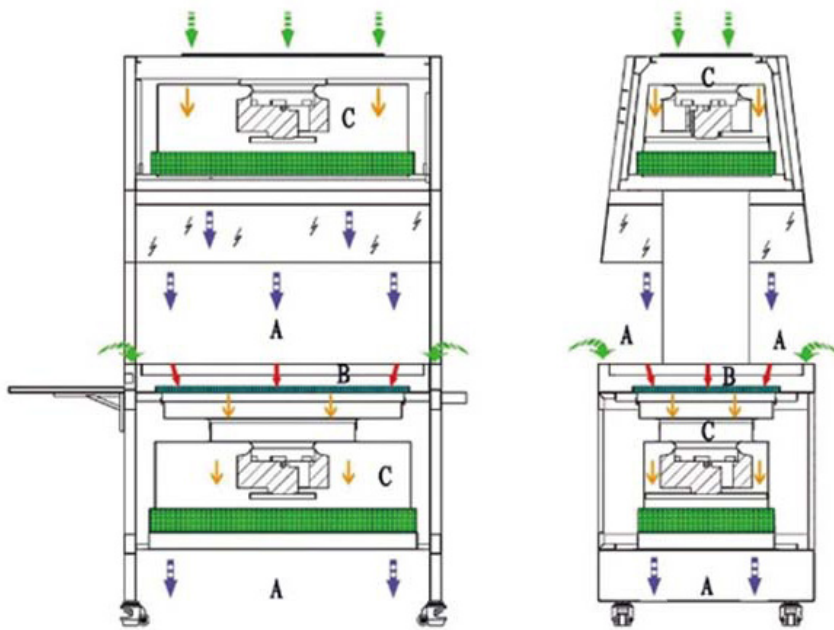

**V-type air grille:**

V-type air grid collects ambient air and combines with vertical laminar downflow to produce an air curtain to protect operators from harmful substances .



**Stainless steel tray:**

The left side of the workstation is equipped with a stainless steel tray for easy placement of experimental supplies.

- Primary Efficiency Filter
- ULPA Filter
- Room Air
- Polluted Air
- Semi-Purified Air
- Purified Air
- A Protected Area
- B Polluted Air
- C Semi- Polluted Air

**Easy to move:**

The Furna caster design and the right side handle design, easy to move the cabinet.



Model	DAW-1100
Power Supply	AC22V±10%, 50/60Hz; 110V±10%, 60Hz
Instrument Size (W*D*H)	1580 x 750 x 1980mm
Operating Area Size (W*D*H)	1015 x 750 x 585mm
Laminar Airflow Velocity	≥0.35m/s
Noise	<65dB
Illuminance	≥1000lx
LED Lamp	12W*2
Consumption (W)	800W
Air Supply ULPA Filter Size	925 x 470 x 69 mm
Exhaust UULP Filter Size	910 x 480 x 69 mm
Primary Filter Size	890 x 480 x 25 mm
Filtration Efficiency	99.9995% (p0.12µm)
Number of Users	1 - 2
Package Size (W*D*H)	1460 x 890 x 2270mm
Gross Weight	243kg