

MOBI fume



Mobile Cyanoacrylate fuming system
for the development of fingers at the
crime scene, in fuming rooms or tents



Only authorised supplier of Attestor products in Australia
VISIT WWW.OPIRA.COM.AU



MOBI fume

Features

Full Control Over Development

Innovative software lets you have full control over your development cycle. Easily connect units and choose cycle settings using our pre-programmed options, or enter custom settings, so you can modify your setup and cycle settings for specific developer types, scenes, and evidence, even if you need to fume multiple areas at once.

Active Humidity Control and Monitoring

During the entire development process, humidity is actively adjusted providing more reliable results. The integrated water reservoir holds enough water even for larger spaces and indicates when it needs to be refilled. The humidifier nozzle at the base of each unit also allows users to direct the moisture airstream, to direct it away from surfaces that may be sensitive to too much moisture.

Integrated Purge System and Filter Management

Each unit comes equipped with an activated carbon filter. After fuming, the system runs a purge cycle, using this filter to remove leftover harmful vapour from the air, making the scene safe to enter.

When filter information for a unit is entered into the program, users can specify the type and amount of developer they're using to better monitor filter life and get the most out of their equipment. The modular design of the units makes it possible to swap out filters quickly when they become saturated, or when users wish to only use a specific filter with one type of developer and need to be able to swap filters for units without any hassle.



User-Friendly Control

Wireless Tablet Control

The touch screen tablet included with every kit can communicate wirelessly with your MOBIfume units as soon as they are connected to power. This means it is easier to seal the fuming space, and makes your scene safer, as there is no need to worry about sealing areas for connection cables between your fuming unit and controller and the wireless feature decreases the number of cables present, cutting down on the risk of tripping or electrical injuries at a scene.

Scalable

Anywhere from 1-99 MOBIfume units can be wirelessly connected to a single tablet. The user-friendly interface makes it easy to connect units and run them individually, or group them together so many can be run at once with the same settings. Users can actively monitor the fuming progress from all their connected units, making it possible to fume a space of any size or shape, or multiple spaces at once. Thanks to the modular nature of the system, different departments that have their own MOBIfume systems can even share their fuming units and connect them all to a single tablet in instances where a larger scene than usual needs to be fumed.

MOBIfume Black Edition

In addition to our basic MOBIfume model, MOBIfume can now be ordered in Black Edition, which features a special black coating. While this black coating is slightly less scratch-resistant than the standard white coating, it is resistant to cyanoacrylate adhesion, making cleaning even easier. Like our standard white units, the Black Edition features tool-less disassembly for easy maintenance.

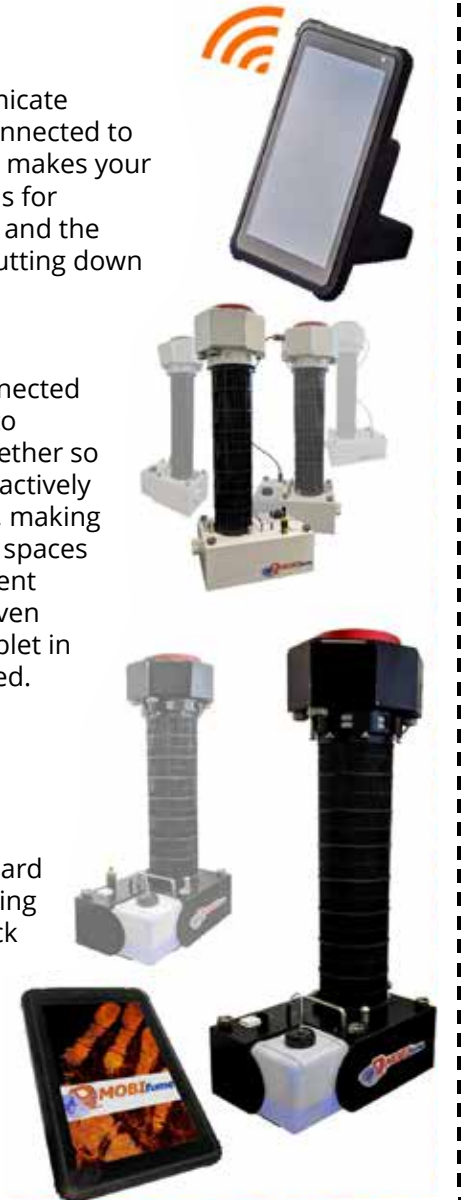

Optional Fuming Tent



Specialized Evidence Tents

For those who want to expand their options, we offer fuming tents. These specialized tents are developed just for forensic use. The durable interior material is easy to wipe clean and exterior helps prevent the interior of the tent from becoming too hot. The black-out interior tent material also makes it ideal for searching for fluorescence from fibers, body fluids, and fluorescent fingerprint developers using ALS.

Tents are sold in two halves which can be erected in minutes and connected together for a large fuming space. Each half can also be used alone if a smaller space is needed. Tents can be placed over large pieces of evidence like vehicles, or can be used to fume many smaller pieces of evidence at once. They can be used right at a scene or set up at a laboratory for labs that do not have full dedicated fuming rooms or garages.

Each tent comes in a sturdy weather resistant carrying case for easy storage and transportation when the tent is not in use.



MOBI fume

Evidence made of non-porous materials like glass, metal, and plastic is frequently encountered in forensics, and developing fingerprints on evidence like this using special fuming chambers has become a standard practice. Pure cyanoacrylate (superglue) and fluorescent one-step developers can adhere to the fingerprints to make them easily visible to the naked eye, make them fluorescent, or make it easier to apply other developers like powder and SPR, all with the end result of giving you high quality prints with better contrast.

While standard laboratory fuming chambers are suitable for many situations, sometimes it is necessary or more practical to fume fingerprints right at a scene instead of transporting all the evidence back to the laboratory first, and some evidence is simply too large to fit in any standard fuming chamber.

MOBifume from Attestor Forensics is a novel portable cyanoacrylate fuming system that is designed to be easy to transport and assemble wherever you are. Up to 99 units can be controlled wirelessly from the user-friendly touch screen tablet included with the system, which allows users to customize the settings and monitor the progress of evidence development all from one convenient device. A single unit can be used to fume a space apx. 50-60 m3, and the ability to connect more units and run them independently or in groups makes it easier to fume larger pieces of evidence in tents and garages, multiple rooms, or develop evidence in larger irregular rooms with a variety of material types in the space.

Each unit features a humidifier with a humidity sensor and a powerful circulation fan for even distribution of humidity and cyanoacrylate developer. This circulation fan is also used to pull air through the integrated activated carbon filter cartridge, removing leftover airborne developer fumes that might be present in the air after the fuming process is finished and re-circulating fresh air.

The system controls the ambient humidity level selected by the user and even keeps this value maintained during the entire fuming process – a quality feature for complex rooms or vehicles where some of the surfaces are semi-porous or porous, which will influence the humidity. A freely adjustable fuming temperature with very large fuming plates also allows users to use other developers aside from standard cyanoacrylate, including a large variety of fluorescent and non-fluorescent cyanoacrylate derivatives in liquid or powder form.

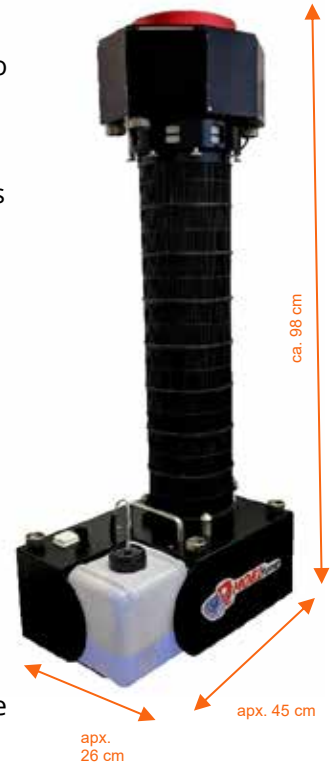

The fully functional basic kit features:

- 2x MOBifume units (each complete with a humidifier base and reservoir system, cyanoacrylate fuming plate with integrated circulation system, and activated carbon filter unit)
- Set of connection Y-cables to supply each MOBifume unit with power
- Control Tablet with touch screen operation to provide wireless control over 1-99 fuming units.
- Full set of heavy duty easy to clean tarpaulin transport bags with handles for ease of sanitation, storage, and transportation of units.
- Note that any basic kit can be ordered in original or Black edition, and can be expanded with additional MOBifume units or extra activated carbon filters.

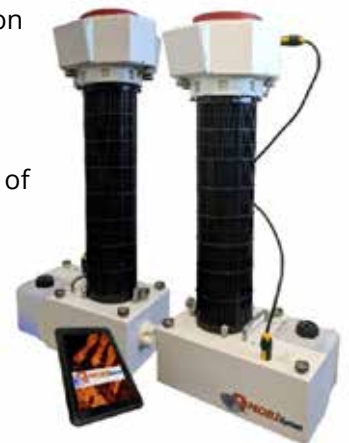

CONTACT OPIRA NOW
1300 157 969
SOLUTIONS@OPIRA.COM.AU

OPIRA BRISBANE
32 DIVIDEND ST
MANSFIELD, QLD 4122

OPIRA MELBOURNE
25 GRAHAM RD
CLAYTON SOUTH, VIC 3169

OPIRA PERTH
9 EARLSTON PLACE
BOORAGOON, WA 6154

OPIRA SYDNEY
20 DUKE ST
FORESTVILLE, NSW 2087

